

Vertical pressure clamping System KOPAL ®

- With neither riser block nor adjusting required, the system allows a continuous adaptation of the clamping height whilst retaining the clamping force with the simple turn of the clamping key.
- Adaptable to all types of machine-tool tables, electro-erosion machines and modular or press T-slot tables (model dependant).
- The clamps are "monobloc" types, which ensure stable, robust and rapid assembly for setting up and dismantling, with a clamping force up to 50000 Newton.

Small machining
and
electro-erosion

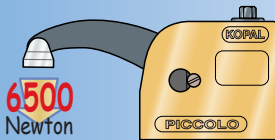

All machining

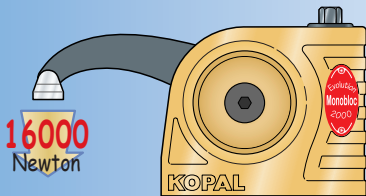

Clamping and lifting

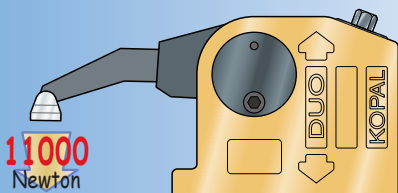

Large machining

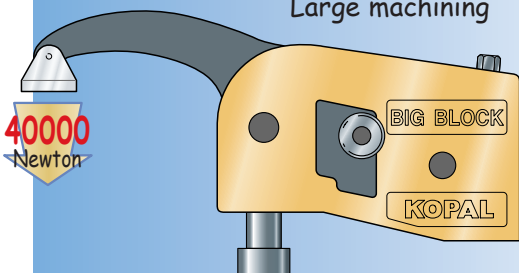

Repetitive machining

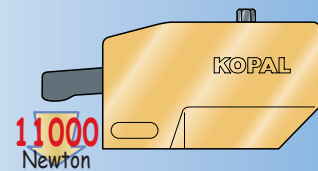

Large machining

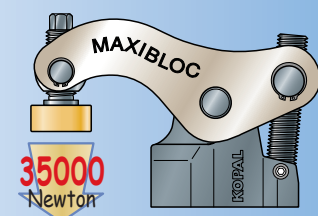

Press clamping

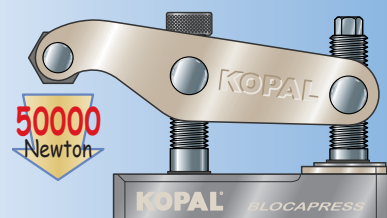

i The choice of a wide range of varied clamps that correspond to the individual's needs

THE FORCE OF EXPERIENCE

Piccolo Clamping Force	Clamping		Ref.
	Reach	Height*	
6500 N.	54	118 mm	07-100

(* with a riser block)

Contents:

- 2 Piccolo
- 2 : 60 mm riser blocks
- 1 : clamping key
- 1 : extra long arm
- 1 : set of 4 multi-shaped swivel shoes
- 4 : M 8 screws
- 6 : M 8 T-nuts with spring
(2 with 12, 14 & 16mm slots)



Monobloc Clamping Force	Clamping		Ref.
	Reach	Height*	
16000 N.	33	154 mm	06-110
12000 N.	61	176 mm	06-100

(* with a riser block)

Contents :

- 2 : Monobloc
- 2 : 74mm riser blocks
- 1 : clamping key
- 1 : extra long arm
- 4 : M 10 screws
- 6 : M 10 T-nuts with spring
(2 with 14, 16 & 18mm slots)



SPECIAL ELECTRO-EROSION

- Quick assembly
- Simplified cleaning mechanism
- Large capacity
- Numerous accessories



Bride
With clamping key and clamping screw, aluminium bronze body, aluminium swivel shoe, arm and steel screw.

Piccolo EDM	Clamping Force	weite	Clamping Height	Torque	Ref.
Short arm	6000 N.	54	-15 to 58 mm	30 N.m	07-022
Long arm	4000 N.	100	-40 to 90 mm		07-023



Riser block and accessories are identical to those of the standard Piccolo.

The only special rapid electro-erosion clamp

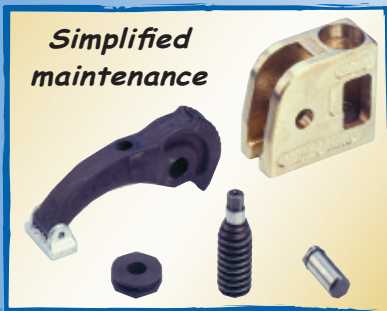

The body has a large opening, which ensures the flow of liquid. The operating mechanism is activated in order to avoid jamming. Dismantling is performed rapidly, without the need for tools, allowing simplified cleaning of the clamp.



ASSEMBLY OF THE STANDARD AND EDM PICCOLO

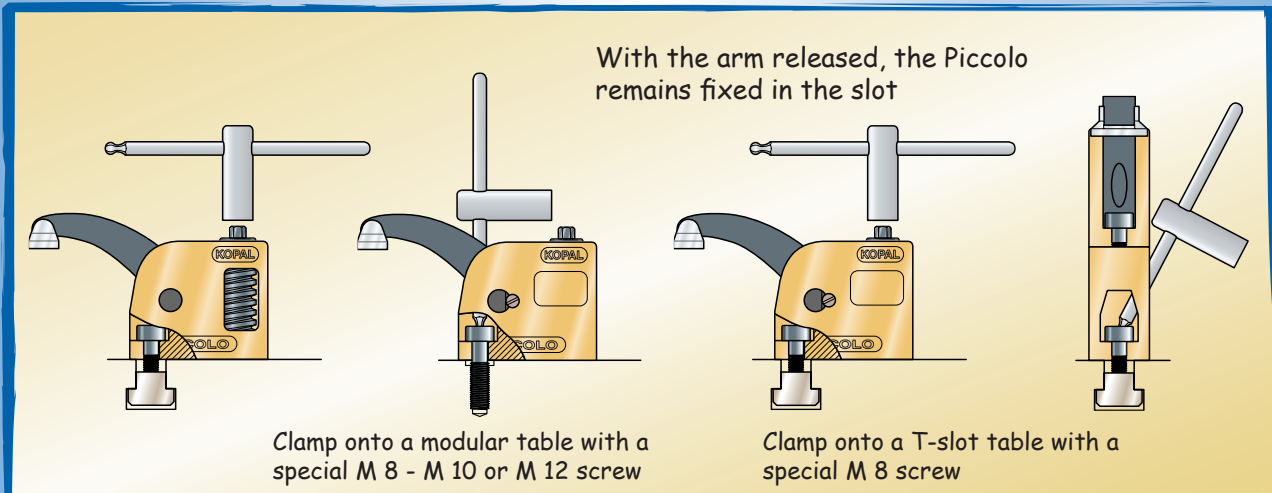

Clamp

With clamping key and clamping screw, aluminium bronze body, aluminium swivel shoe, arm and steel screw



Piccolo	Clamping Force	Reach	Clamping Height	Torque	Ref.
Short arm	6500 N.	54	-15 to 58 mm	30 N.m	07-020
Long arm	4200 N.	100	-40 to 90 mm		07-025

Nickel-plated clamping key

07-180

*Clamping power
Compact
Numerous accessories*

Use:
Tee-slot tables
Modular tables

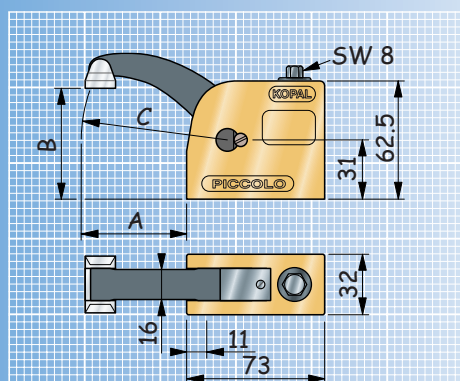

Piccolo	A	B	C
07-020	54	-15 à 58	R 76
07-025	100	-40 à 90	R 122

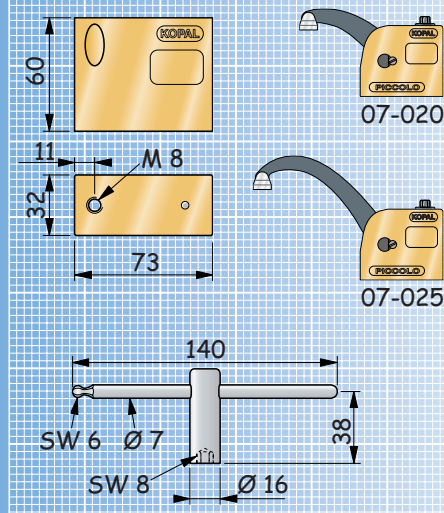

Particularly with drills, you will appreciate the practicality of a clamp that has exceptional strength for such a compact size.



Piccolo fittings

Clamping screw	Ref.
M 8 x 30 mm (standard)	07-720
M 10 x 35 mm	07-730
M 12 x 35 mm	07-735

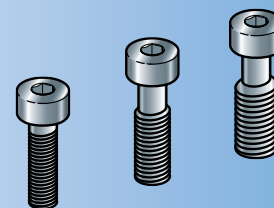

Aluminium riser block 07-030

These 60 mm riser blocks can be stacked in order to clamp very tall workpieces.

Delivered with clamping screws

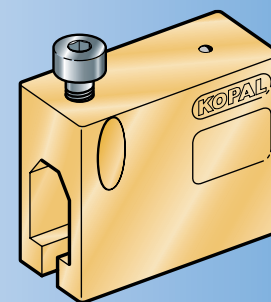

Piccolo Boxed set	Clamping Force	Reach	Clamping Height	Ref.
Short arm (* with a riser block) Contents page 29	6500 N.	54	0 to 118 mm	07-100



T-nuts for M8 T-slots

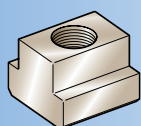

Ref.	Ref.	Ref.	Ref.	Ref.
10 mm	12 mm	14 mm	16 mm	18 mm
90-050	90-055	90-060	90-065	90-070

Multi-purpose
Ultra-quick clamping
New ergonomic key
Clamping power

VERSATILE



Clamp with clamping key as well as
 Fixing screws in addition.
 Aluminium swivel shoe and body, steel cam.

*Fixing by screws, the clamp
 has a fixed positioning*

Monobloc	Clamping Force	Reach	Clamping Height	Torque	Ref.
Short arm	16000 N.	33	0 to 80 mm	80 N.m	06-020
Long arm	12000 N.	61	- 8 to 102 mm	80 N.m	06-030
XXL arm	8000 N.	132	- 43 to 155 mm	80 N.m	06-035



Coated clamping key, 58 mm in height (Standard) **06-160**
 Nickel-plated clamping key, 88mm in height (with XXL cam) **06-325**

- 1 Slide the T-nut and the screw into the slot
- 2 Position and tighten the clamp onto the table using the clamping key provided
- 3 Clamp the workpiece using the same key
- 4 Proceed to machining

Why the Monobloc :
Tables with T-slots
Tapped hole tables
 With the arm released, the Monobloc remains fixed in the slot

Fixing onto modular table with a special screw :
 M10 - M 12 - M 14 order M 16

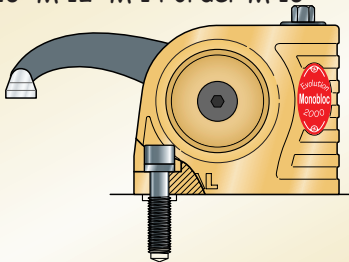

Fixing onto T-slot table with special M10 screw

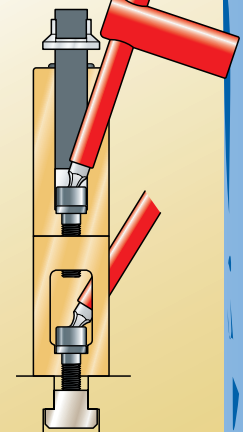
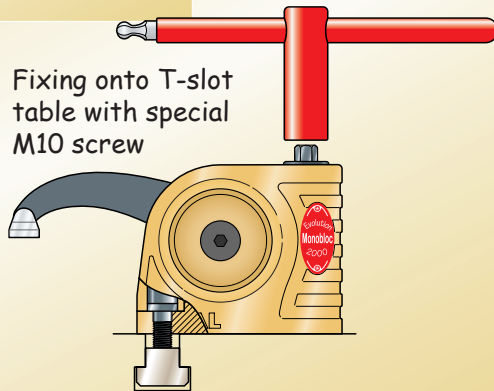

Monobloc Box set	Clamping Force	Reach	Clamping Height*	Ref.
Short arm	16000 N.	33	0 to 154 mm	06-110
Long arm	12000 N.	61	- 8 to 176 mm	06-100

(*with riser block)

Contents : **2 Monobloc, 2 Riser blocks,**
 1 clamping key, 1 extra-long arm,
 4 : M 10 screws, 6 : M 10-nuts with spring (for 14, 16 & 18mm slots)



Monobloc fittings

		Ref.
M 10 Clamping screw		
M 10 x 35	for slot 12 and 14 mm	06-080
M 10 x 40	16 and 18 mm	06-085
M 10 x 45	20 and 22 mm	06-090
Clamping screw		
M 12 x 40	for tapped holes M 12	06-065
M 14 x 45	M 14	06-070
M 16 x 45	M 16	06-075

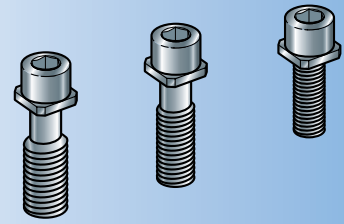

Aluminium riser block 74 mm **06-050**
 These riser blocks can be stacked in order to clamp very tall workpieces.
 Delivered with M 10 x 35 mm clamping screw.

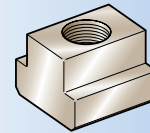
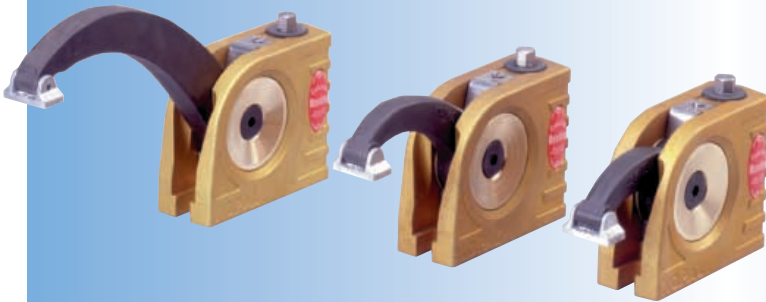
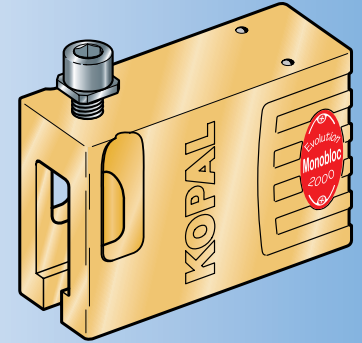

M 10 T-nuts	
Slot	Ref.
12 mm	90-100
14 mm	90-105
16 mm	90-110
18 mm	90-115
20 mm	90-120
22 mm	90-125
24 mm	90-130
28 mm	90-135

Allen ball key for clamping screw

Monobloc	A	B	C
06-020	33	0 to 80	R 77
06-030	61	-8 to 102	R 105
06-035	132	-43 to 155	R 176

Key		L	d	D
06-160	Coated	58	14	24
06-325	Nickel-plated	88	10	20



The extra-long cam clips onto the clamp and increases the reach up to 90 mm.

Accessories	Ref.
Extra-long arm	05-140
Set of 4 multi-shaped aluminium swivel shoes	06-150

Zubehör Seite 38

Swivel shoe N°2
 Ref. 06-802



KOPAL BLOC BRIDE VERTICAL CLAMPING SYSTEM

Multi-purpose
Ultra-quick assembly and changing
of workpieces
Multiple accessories



Clamp

With clamping key and swivel shoe, steel arm and screw, aluminium body.

Bloc bride (Arm)	Clamping Force	Reach	Clamping Height	Torque	Ref.
Short arm	16000 N.	33	0 to 80 mm	80 N.m	05-020
Long arm	12000 N.	61	- 8 to 102 mm	80 N.m	05-030
XXL arm	8000 N.	132	- 43 to 155 mm	80 N.m	05-035

Remember to order the fixing set (T-nut, screw and spring), which corresponds to the width of your machine's slots

Coated clamping key 58 mm in height (standard)

05-180

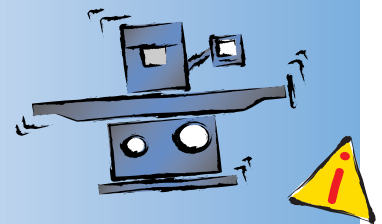

Safe clamping is an important element for the user's safety

Record installation and clamping time



Why the Bloc Bride :

Tables with T-slots

Drill / Milling machine
 With the arm released, the Bloc Bride should slide into the slot.

- 1 Slide the clamp into the slot, in position for clamping the workpiece
- 2 Directly clamp the workpiece using the clamping key provided
- 3 Proceed machining

Assemble onto the sliding component with an oscillating seat (09-456)

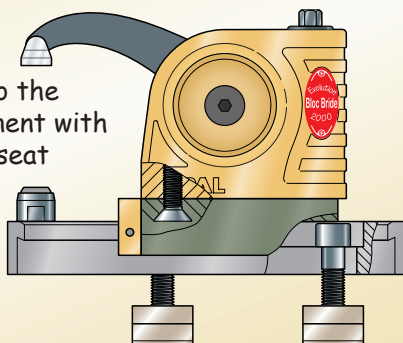

Adjust the position of the clamp's or riser block's T-nut in relation to the slot, leaving the least possible clearance

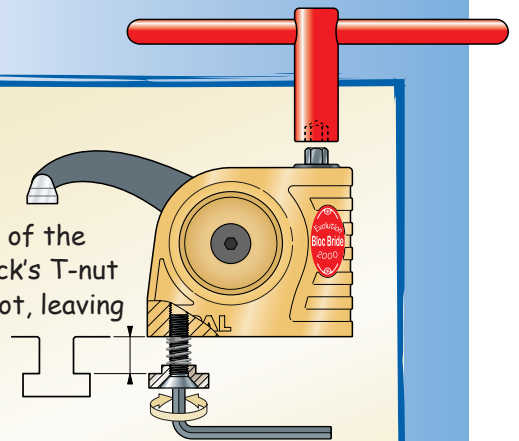

Extend the clamping reach up to 90 mm with the extra-long arm (05-140)

Assemble onto the riser block (06-050)

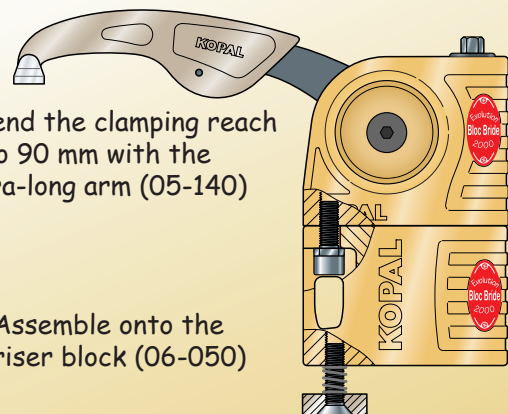

VERTICAL CLAMPING SYSTEM *BLOC BRIDE* KOPAL

Bloc Bride fittings Ref.

Fixing set

Special T-nuts, TF screws and spring

For slots :

12 mm	05-200
14 mm	05-205
16 mm	05-210
18 mm	05-215
20 mm	05-220
22 mm	05-225

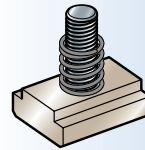

74 mm aluminium riser block Ref. **06-050**

These riser blocks can be stacked in order to clamp very tall workpieces.

Delivered with clamping screw.

The clamp's special T-nut is the one to be used

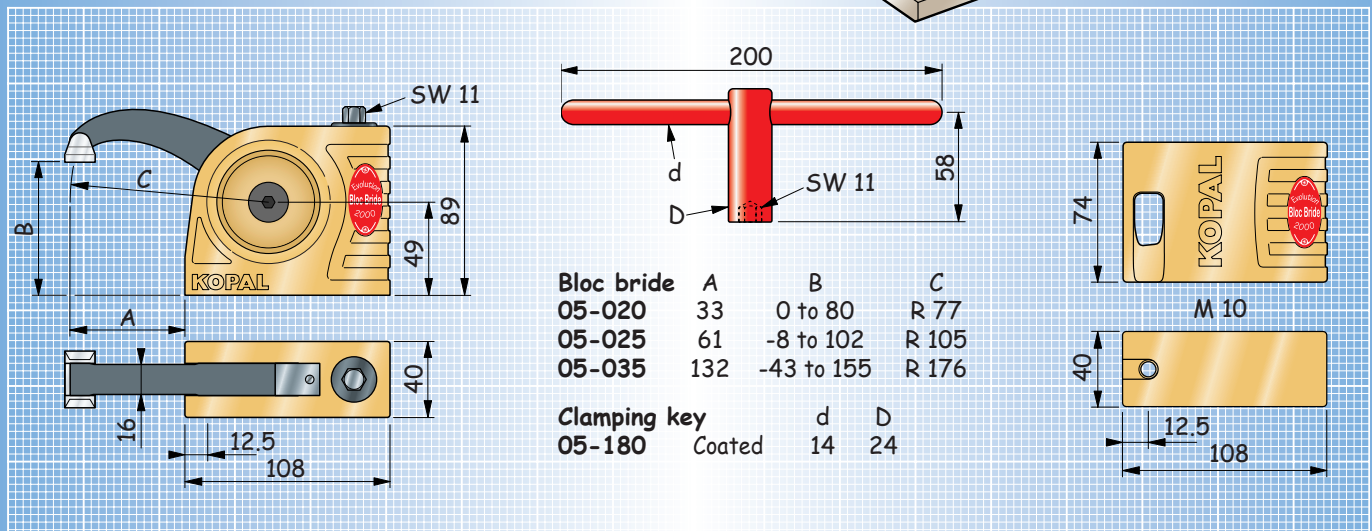
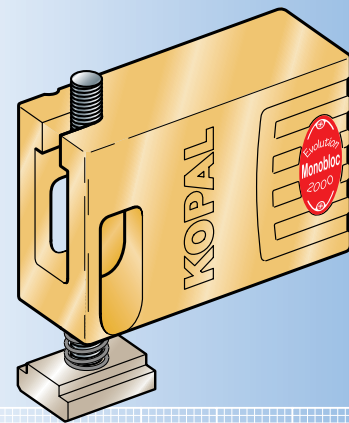

Accessories Ref.

Sliding component Ref. **09-456**

Set of 4 multi-shaped aluminium swivel shoes Ref. **06-150**

Swivel shoe No 4
Ref. 06-804



Adjustable clamping range
Lifting and Clamping
2 interchangeable arms of different shapes
Accessories common to the range

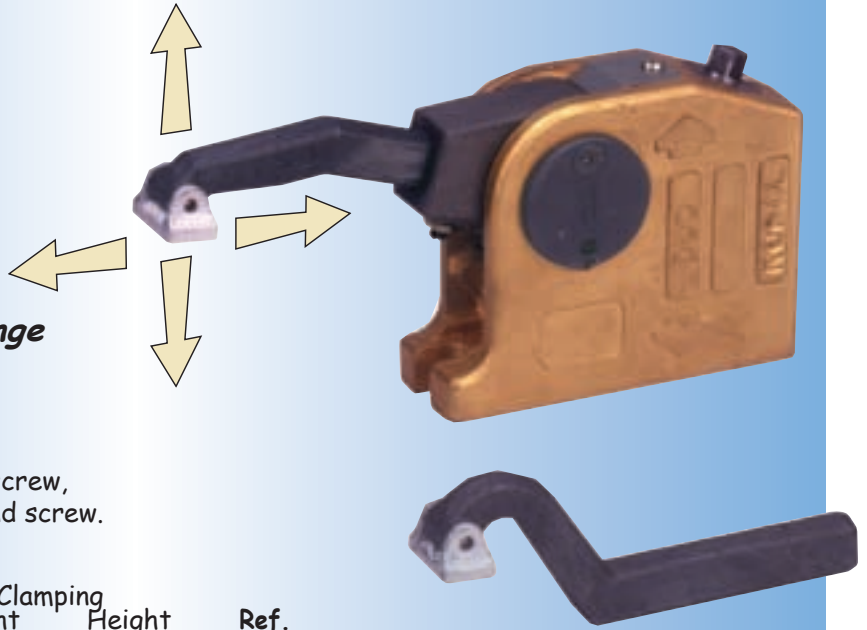

Clamp

With 2 arms, 1 clamping key and 1 clamping screw, aluminium swivel shoe and body, steel arm and screw.

Duo	Clamping Force	Reach	Clamping Height	Clamping Height	Ref.
	11000 N.	46 to 91	0 to 129	4 to 142 mm	21-020
					06-050
					06-160

74 mm aluminium riser block

Coated clamping key, 58mm in height (standard)

Use :
Tables with T-slots
Modular tables

- 1 Slide the T-nut and screw into the slot
- 2 Position and tighten the clamp onto the table using the clamping key provided
- 3 Clamp the workpiece using the same clamping
- 4 Proceed machining

With the arm loose, the Duo remains fixed in the slot

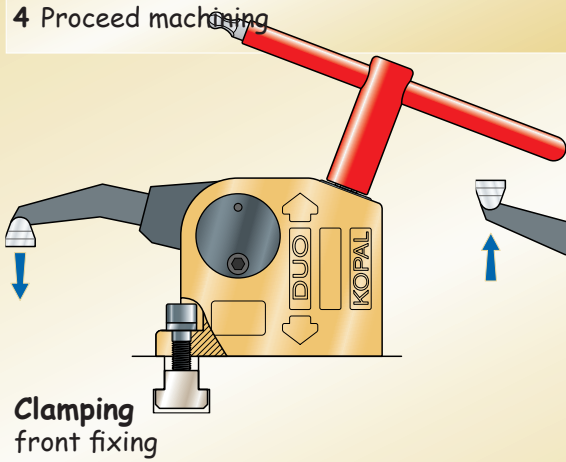

Fix on T-slot table with special M10 screw

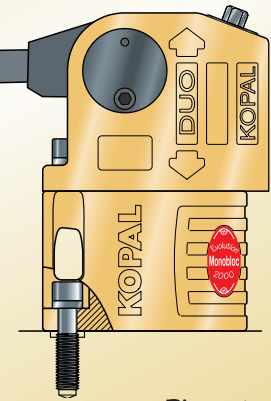
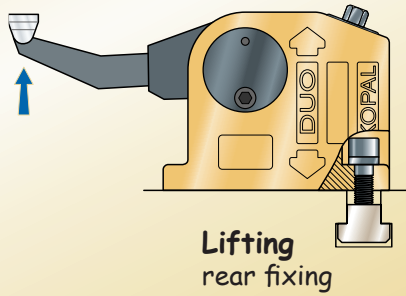

Fix onto modular table with a special screw:
M10 - M 12 - M 14 - M 16

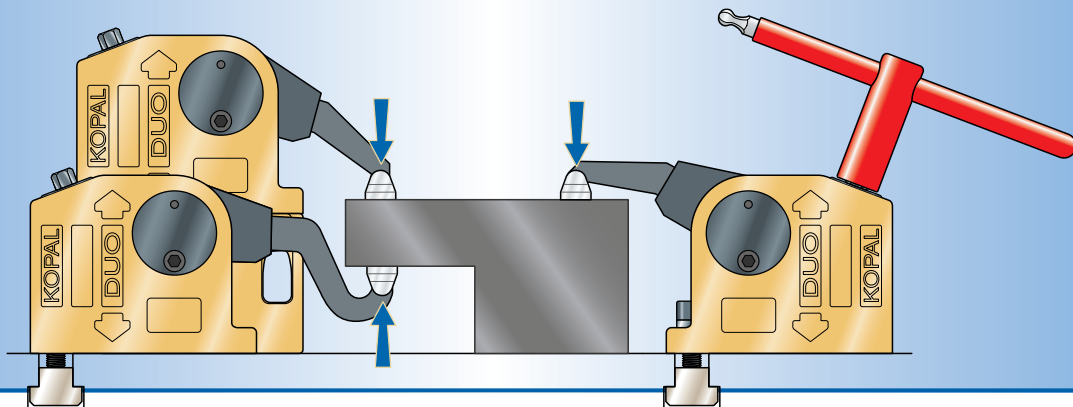

Fixture

Ref.

M 10 clamping screw		for slots	
M 10 x 35		12 und 14 mm	06-080
M 10 x 40		16 und 18 mm	06-085
M 10 x 45		20 und 22 mm	06-090
clamping screw		for tapped holes	
M 12 x 40		M 12	06-065
M 14 x 45		M 14	06-070
M 16 x 45		M 16	06-075

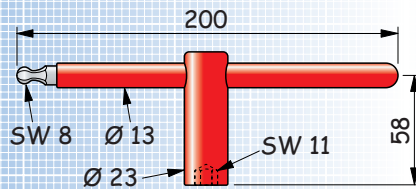
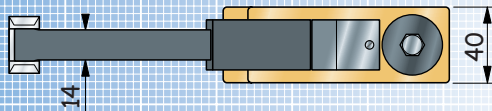
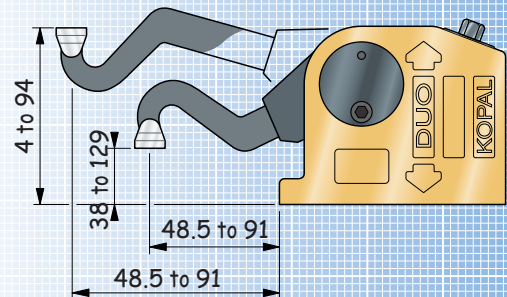
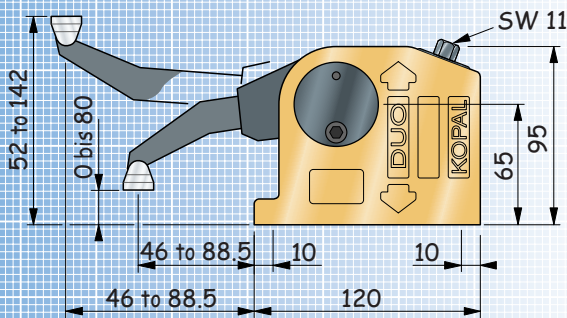

06-050

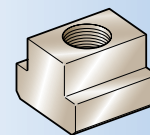
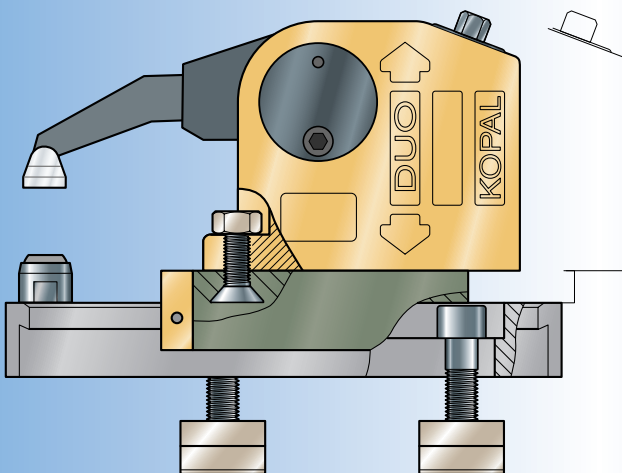
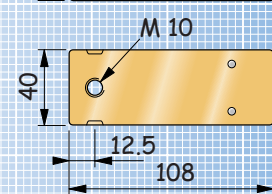
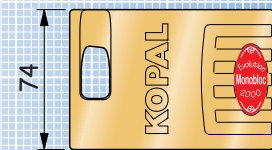

M 10 T-nuts

Slot	Ref.
12 mm	90-100
14 mm	90-105
16 mm	90-110
18 mm	90-115
20 mm	90-120
22 mm	90-125
24 mm	90-130
28 mm	90-135

Sliding component allows the clamp to quickly retract (09-456).

Accessories

Ref.

Sliding component	09-456
Set of 4 multi-shaped aluminium swivel shoes	06-150



ACCESSORIES

VERTICAL CLAMPING SYSTEM



Ref.

Sliding component

09-456

Quickly retracts the clamp
2 x M 12 fixing screws.

Includes :

- Slide bar (cast iron) 05-150
- With oscillating seat, adjustable stop and clamping screw
- Slide (Aluminium) 09-195
- With screw for fixing the clamp

*Accessories common to the
Piccolo, Monobloc, Bloc
Bride and Duo.
More options
More capacity*

Extra-long arm

Retractable arm.

Increase the clamping reach up to 90 mm.

05-140



06-802



06-803



05-565



06-804

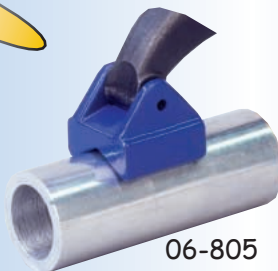

06-805

Aluminium swivel shoe No .

New shape

Standard swivel shoe

05-565

5 part 06-152

Set of 4

06-150

multi-shaped blocks

Aluminium interchangeable swivel shoes

Set includes :

- 1 Shoe N° 2 06-802
- Longitudinal
- 1 Shoe N° 3 06-803
- Transverse
- 1 Shoe N° 4 06-804
- Transverse V
- 1 Shoe N° 5 06-805
- Longitudinal V

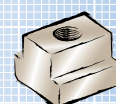
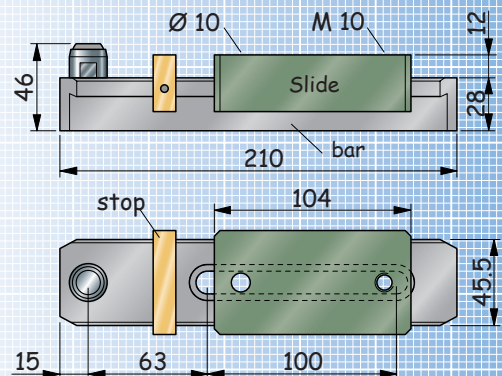
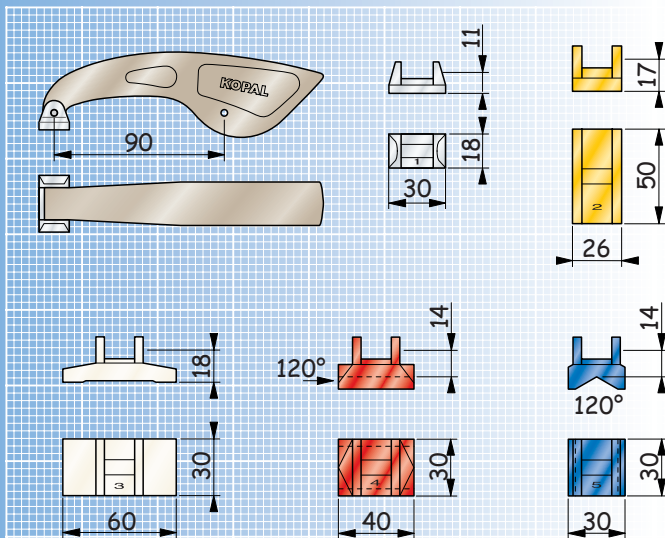

Fixing T-nuts and screws on page 47

Substantial clamping height
4 different models
Quick assembly



Clamp
With clamping key, swivel shoe and adaptor,
steel cam, aluminium body.

Big Block	Clamping	Reach	Clamping Height	Torque	Ref.
	40000 N.	50	12 bis 80 mm	70 N.m	08-020
	28000 N.	95	- 12 bis 100 mm	70 N.m	08-030
	20000 N.	145	- 18 bis 135 mm	70 N.m	08-035
	14000 N.	245	- 50 bis 155 mm	70 N.m	08-038

Clamping key

08-160

Use :
Tables with T-slots
Milling machines

i With the arm released, the Big-block can either be fixed in the slot, or sliding.

Assemble directly onto the table (without base or riser block), with a stud with cylinder (sold separately)

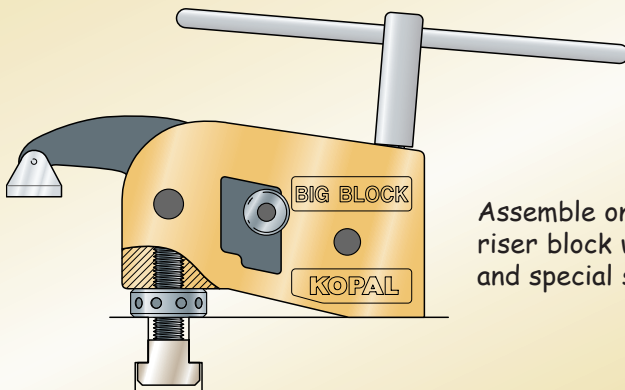

Quick assembly and dismantling

Assemble onto base and riser block with adaptor and special stud

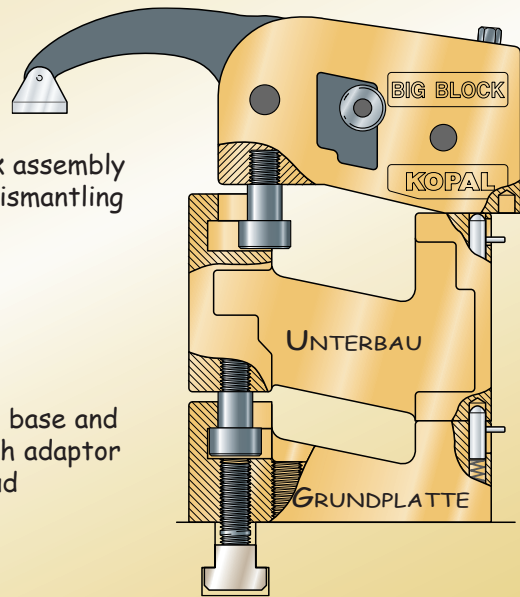

5-position indexing of the arm in order to quickly adapt to the clamping height.

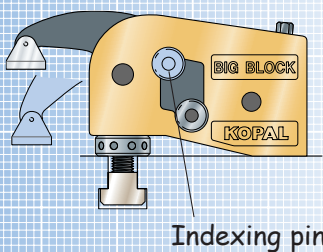

Indexing pin



KOPAL *BIG BLOCK* VERTICAL CLAMPING SYSTEM

Special studs with cylinder Ref.

Fixes the Big Block directly onto the table

V2-C1	M 14 x 62 mm	08-060
V2-C1	M 14 x 82 mm	08-070
V2-C2	M 16 x 70 mm	08-080
V2-C2	M 16 x 80 mm	08-090

Special studs

Fixes the base onto the table

V2-1	M 14 x 60 mm	08-100
V2-1	M 14 x 80 mm	08-110
V2-2	M 16 x 65 mm	08-120
V2-2	M 16 x 85 mm	08-130

Riser block N°1 55 mm 08-045

Riser block N°2 110 mm 08-050

Riser block N°3 330 mm 08-055

With an adaptor

55 mm aluminium base

With a M 16 x 65 mm fixing stud 08-040

Swivel shoes

Standard aluminium shoe 08-330

100 mm steel wide shoe 08-210

130 mm steel wide shoe 08-215

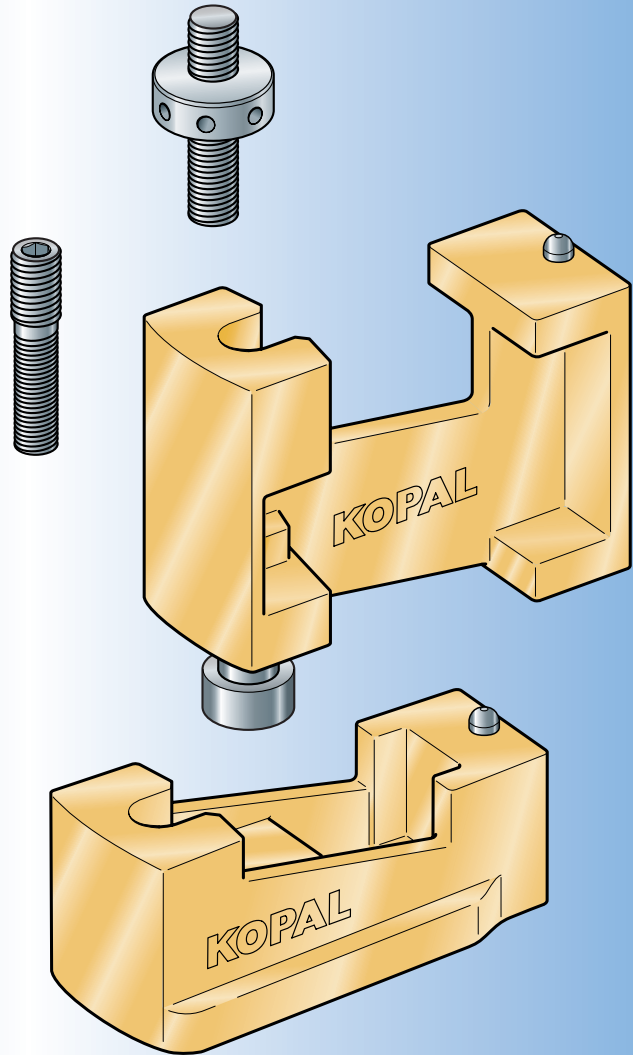

T-nuts for T-slots

Slot	M 14 Ref.	M 16 Ref.
16 mm	90-200	
18 mm	90-205	90-250
20 mm	90-210	90-255
22 mm	90-215	90-260
24 mm	90-220	90-265
28 mm	90-225	90-270

Sliding equipment

08-180

With bar, slide, support for adjustable component and 2 x M16 fixing screws

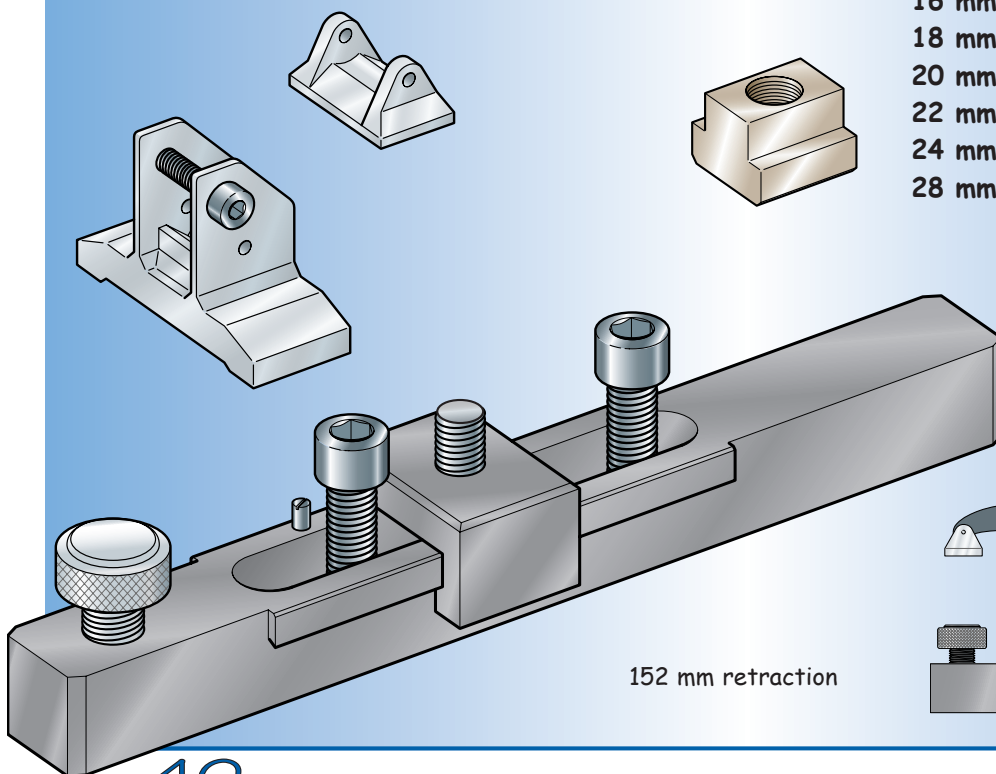

152 mm retraction

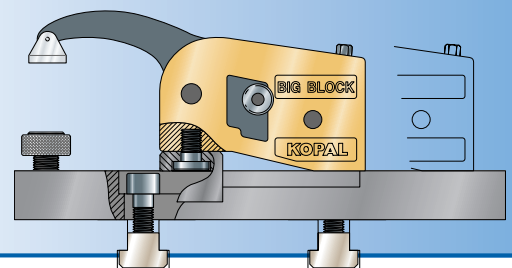

The choice

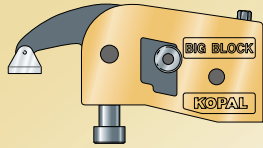

08-020

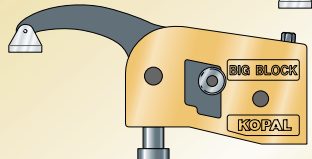

08-030

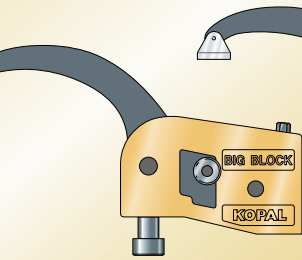

08-035

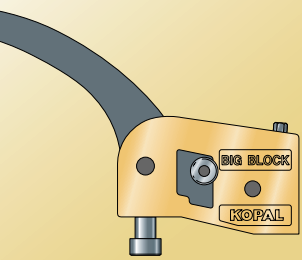

08-038

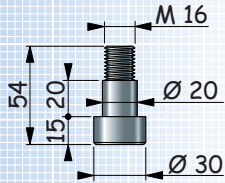
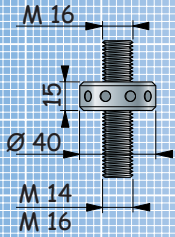

Big Block	A	B	C
08-020	50	12 to 80	R 75
08-030	95	-12 to 100	R 120
08-035	145	-18 to 135	R 170
08-038	245	-50 to 155	R 270

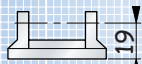
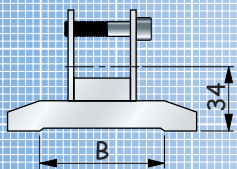
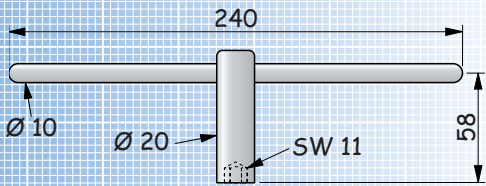
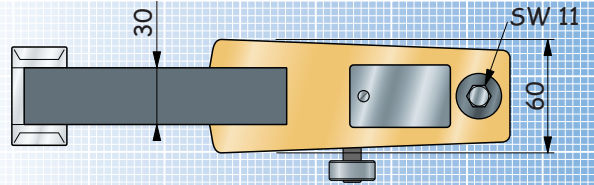
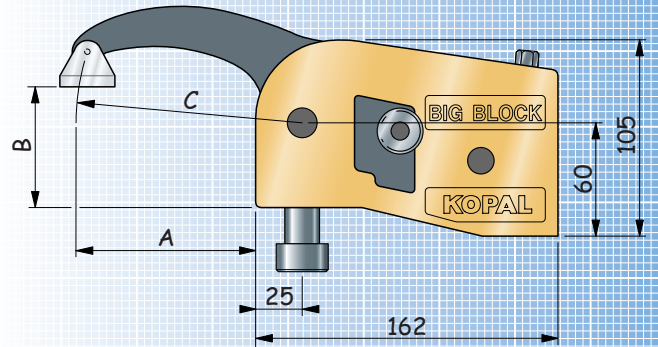

Swivel shoes	A	B
08-330	52	
08-210	100	68
08-215	130	90

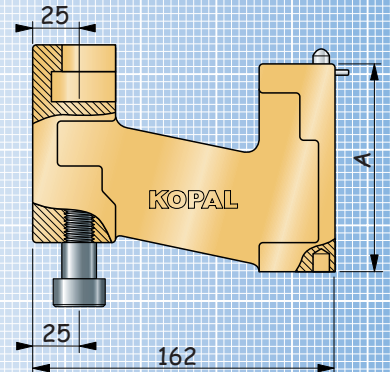
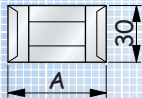
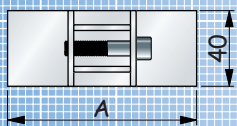

Riser blocks	A
08-045	55
08-050	110
08-055	330

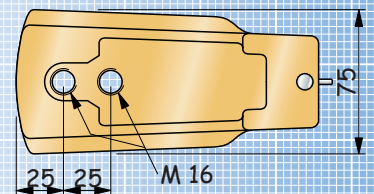
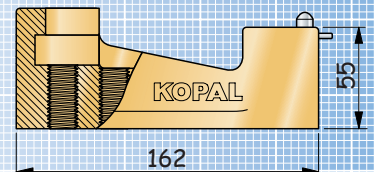
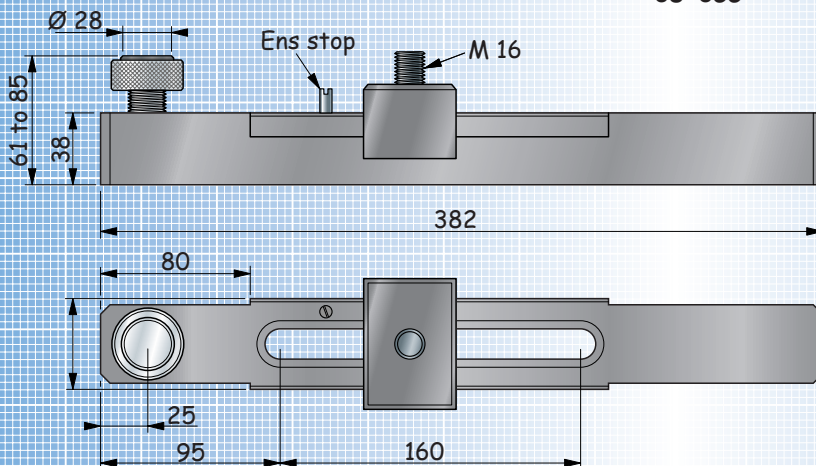
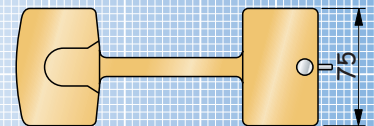

CLAMP WITH RETRACTABLE ARM

Clamp with combined actions
 Cam retraction
 Extremely compact clamp
 Ultra-quick action



Clamp
 With clamping key and M10 x 35 mm clamping screw,
 aluminium body, steel arm.



Record tightening and loosening time

Terrific	Clamping Force	Reach	Clamping Height	Torque	Ref.
	11000 N.	30	22 to 26 mm	20 N.m	23-020
Clamping key					23-150

Use :
 For series assemblies

Principle :

- The turning of the key makes it possible to achieve 2 movements :
- A horizontal movement places the clamping arm into position for clamping.
 - A vertical movement performs the clamping of the workpiece.

Continuous turning of the key

The arm is retracted into the body

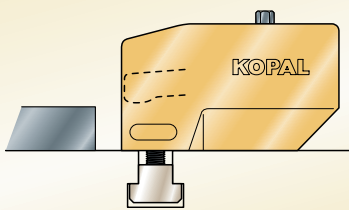

Changing of the workpiece

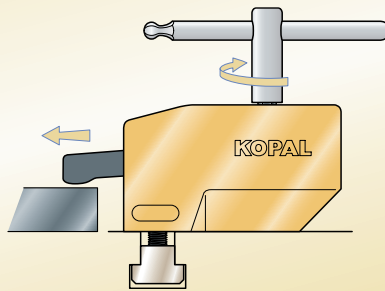

Extension of the arm

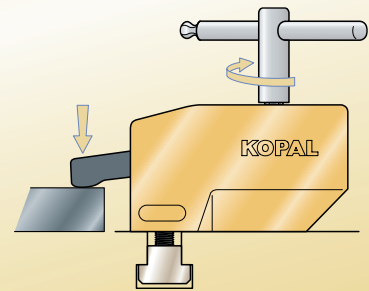

Clamping of the workpiece

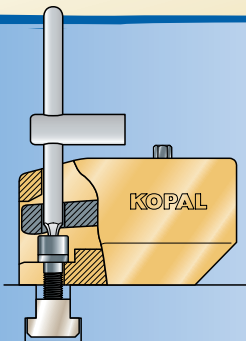

Simple and quick fixing with M 10 screw (provided)

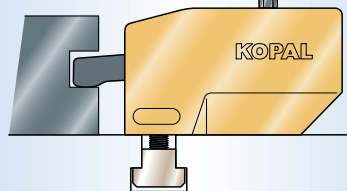

Compact clamp taking up very little space

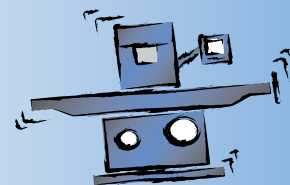

A mechanical clamp, perfectly adapted to the series, requiring an extremely quick changeover of the workpiece

Ausrüstungen Terrific

Ref.

M 10 Fixing screw

M 10 x 35

M 10 x 40

M 10 x 45

for slots

12 und 14 mm

16 und 18 mm

20 und 22 mm

06-080

06-085

06-090

Fixing screw

M 12 x 40

M 14 x 45

M 16 x 45

for tapped holes

M 12

M 14

M 16

06-065

06-070

06-075

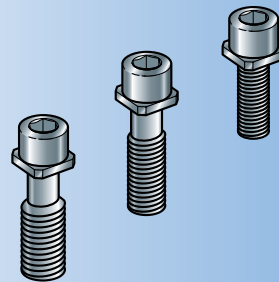

Set of 6 riser blocks

23-080

Aluminium riser blocks delivered with 6 x M10 screws of varied lengths.

They raise the clamping height of Terrific up to 126mm

Riser blocks thickness : 2 - 4 - 8 - 16 - 32 - 64 mm.

M 10 x : 45 - 50 - 60 - 75 - 100 - 120 mm.

Match the length of the screw with regard to the height of the riser block used.

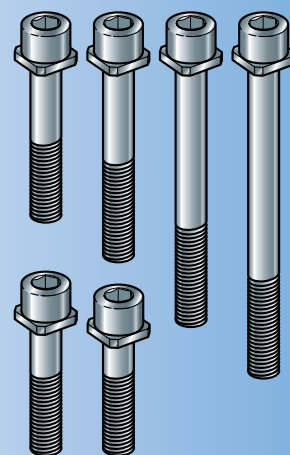
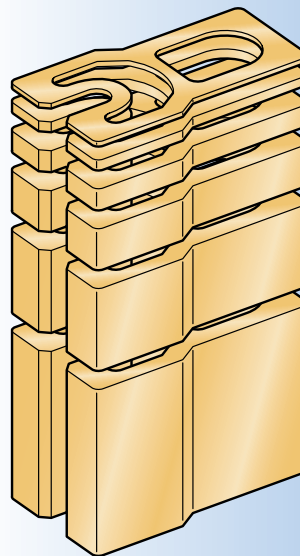

Fixture - Riser blocks

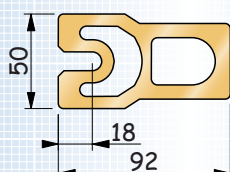
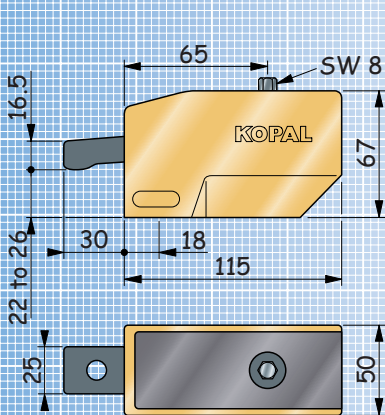
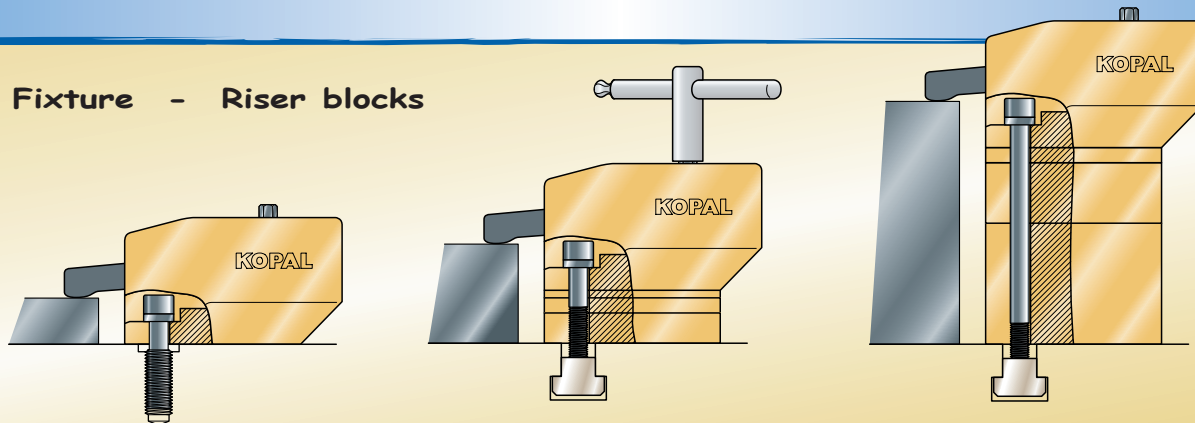

Riser blocks thickness :
2 - 4 - 8 - 16 - 32 - 64 mm

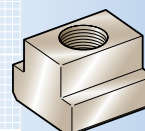
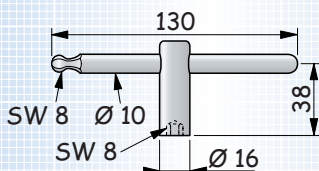

M 10 T-nuts

Slot Ref.

12 mm	90-100
14 mm	90-105
16 mm	90-110
18 mm	90-115
20 mm	90-120
22 mm	90-125
24 mm	90-130
28 mm	90-135

Steel clamp for large machinings
Powerful clamping
Retracting cam
Extremely compact clamp



Maxibloc

With clamping key, extension key and special clamping screw. Steel clamping body and arm.

Clamping Force	Reach	Clamping Height	Torque	Ref.
35000 N.	50	86 mm	70 N.m	06-310
Nickel-plated clamping key 88 mm in height				06-325
Extension key				06-726



For T-slot tables from 16 mm and M 14 and M 16 modular tables.
 Fixing with 1 screw.
 Compact clamp with direct clamping of workpiece.
 Very simple adjustment and retraction of the clamping arm.

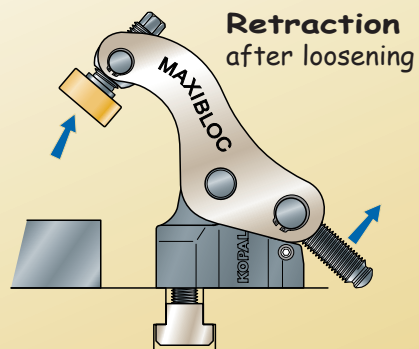
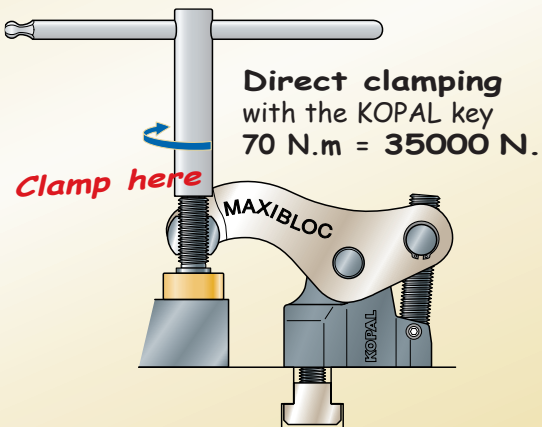
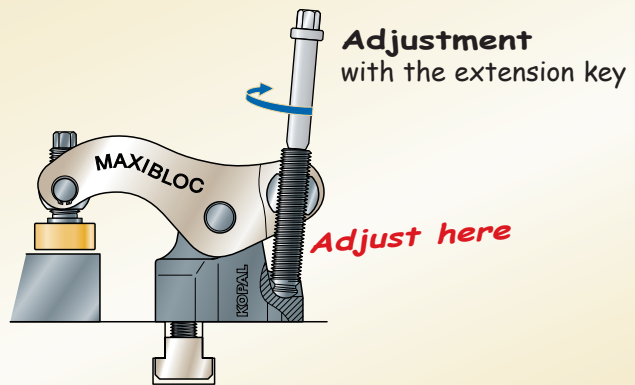
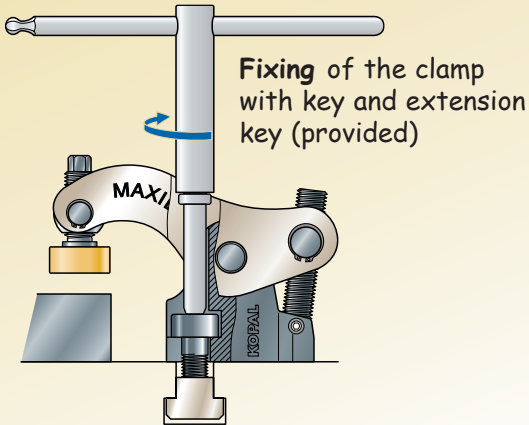

Fixing screw

Ref.

Special 8 mm hexagonal large head screws,

M 14 x 40 mm

06-720

M 16 x 44 mm

06-721

M 16 x 60 mm

06-723

Riser block

Steel stackable riser block, delivered with a M 14 fixing screw

80 mm riser block

06-320

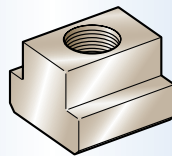
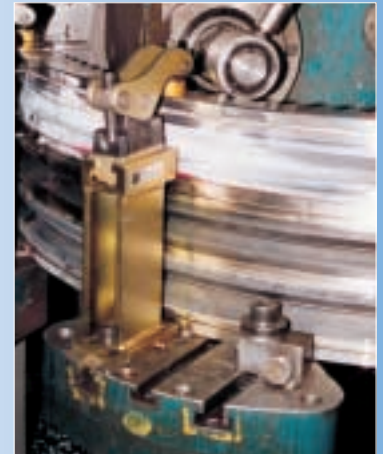
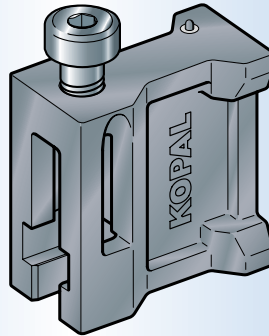
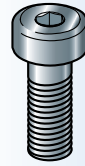

T-nuts
Slot

M 14
Ref.

M 16
Ref.

16 mm

90-202*

18 mm

90-205

90-250

20 mm

90-210

90-255

22 mm

90-215

90-260

24 mm

90-220

90-265

28 mm

90-225

90-270

* long T-nut

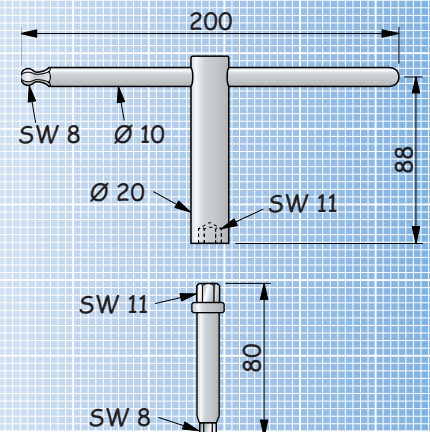
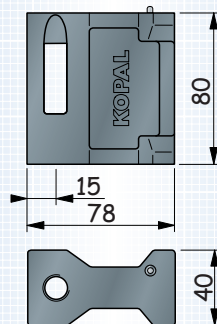
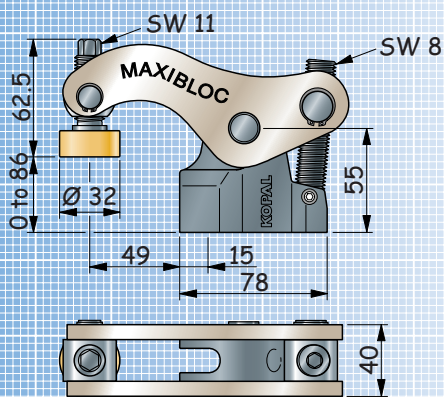
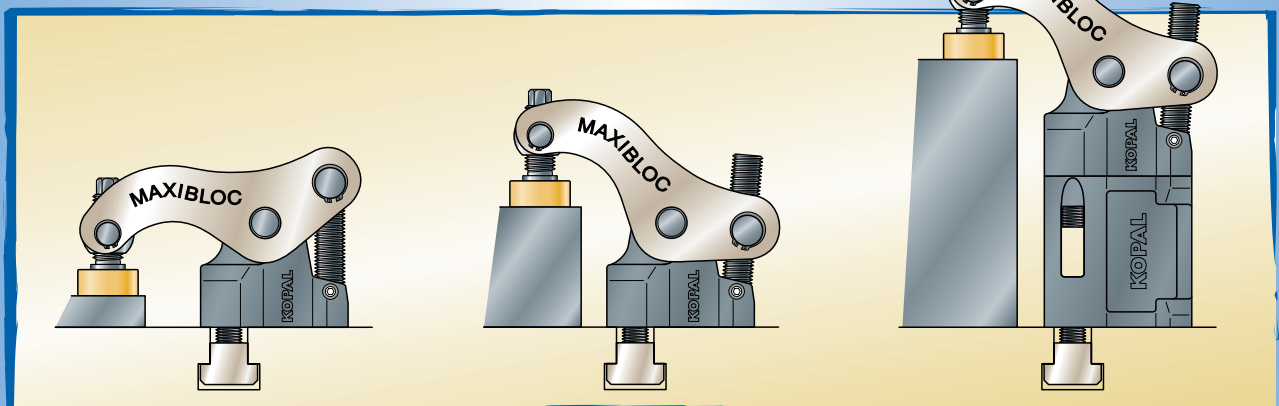

KOPAL BLOCAPRESS VERTICAL CLAMPING SYSTEM

For very powerful presses
 Entirely in hardened steel
 Extremely powerful mechanical resistance



Blocapress

Clamping Force	Reach	Clamping Height	Torque	Ref.
50000 N.	30	14 to 92 mm	90 N.m	08-340

clamping key and screw sold separately

50000
 Newton

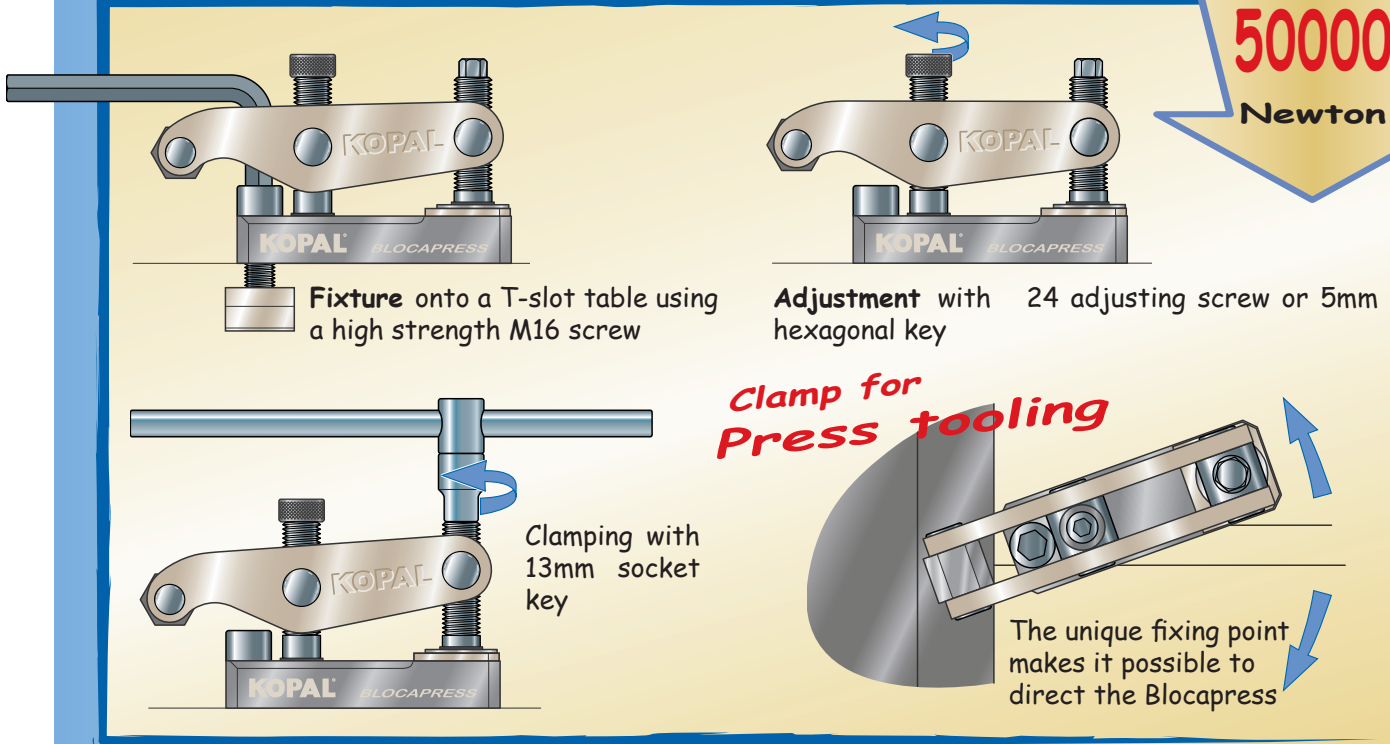

Ref.

Set of 3 clamping keys

08-342

- Includes :
- 1 sliding handle (1/2" square)
 - 1 hexagonal socket 13 mm
 - 2 male hexagonal keys : 5 and 14mm

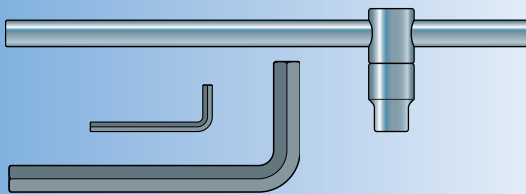

- M 16 fixing screw
- Class 12.9 (ISO-Standard)
- M 16 x 60 mm screw
- M 16 x 80 mm screw

99-682
 99-684

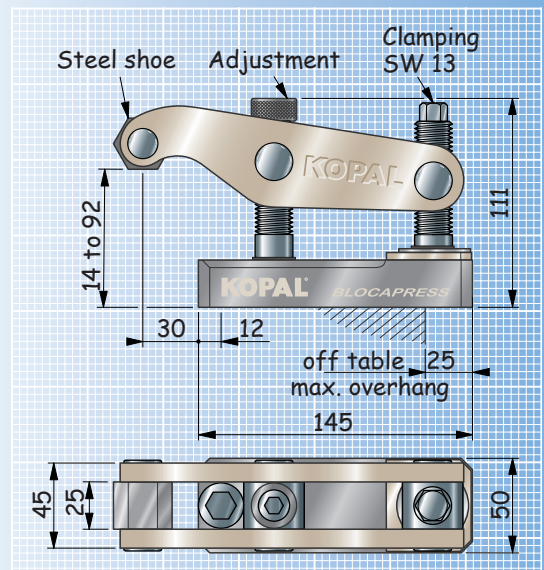

Screws for Monobloc - Duo - Terrific Ref.

Fixing screw	for slots	Ref.
M 10 x 35	12 und 14 mm	06-080
M 10 x 40	16 und 18 mm	06-085
M 10 x 45	20 und 22 mm	06-090

Fixing screw	for tapped holes	Ref.
M 12 x 40	M 12	06-065
M 14 x 45	M 14	06-070
M 16 x 45	M 16	06-075

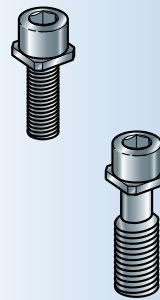

Important
Always use KOPAL special screws

Screws for Bloc Bride Ref.

Special T-nuts, TF screws and spring	Ref.
12 mm slot	05-200
14 mm slot	05-205
16 mm slot	05-210
18 mm slot	05-215
20 mm slot	05-220
22 mm slot	05-225

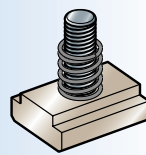

Screws for Piccolo Ref.

M 8 x 30 mm	07-720
M 10 x 35 mm	07-730
M 12 x 35 mm	07-735

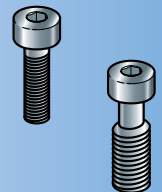

Screws for Maxibloc Ref.

M 14 x 40 mm	06-720
M 16 x 44 mm	06-721
M 16 x 60 mm	06-723

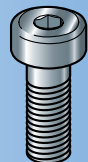

Screws for Big Block Ref.

Special studs with cylinder

fixes the Big Block onto the table

V2-C1 M 14 x 62 mm	08-060
V2-C1 M 14 x 82 mm	08-070
V2-C2 M 16 x 70 mm	08-080
V2-C2 M 16 x 80 mm	08-090

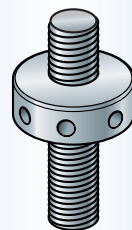

Special studs

fixes the base onto the table

V2-1 M 14 x 60 mm	08-100
V2-1 M 14 x 80 mm	08-110
V2-2 M 16 x 65 mm	08-120
V2-2 M 16 x 85 mm	08-130

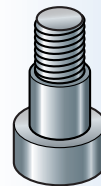

Adapter

Fixes the Big Block onto riser blocks and the base

Adapter	08-140
---------	--------

T-nuts for T-slots

Slot	M 8 Ref.	M 10 Ref.	M 12 Ref.	M 14 Ref.	M 16 Ref.
10 mm	90-050				
12 mm	90-055	90-100			
14 mm	90-060	90-105	90-150		
16 mm	90-065	90-110	90-155	90-200	
18 mm	90-070	90-115	90-160	90-205	90-250
20 mm		90-120	90-165	90-210	90-255
22 mm		90-125	90-170	90-215	90-260
24 mm		90-130	90-175	90-220	90-265
28 mm		90-135	90-180	90-225	90-270

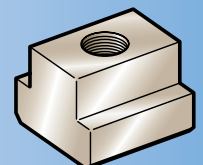

Piccolo

Ref.

Worm screw

1 screw, 1 smooth ring

07-310

54 mm arm

07-315

100 mm arm

07-318

Clamping key

07-180

Swivel shoe

05-565

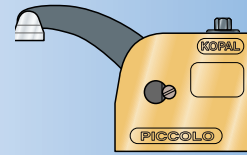

Monobloc - Bloc Bride

Worm screw

1 screw, 1 smooth ring

05-310

33 mm arm

05-315

61 mm arm

05-320

132 mm arm

05-322

Monobloc Clamping key

06-160

Bloc Bride Clamping key

05-180

Swivel shoe

05-565

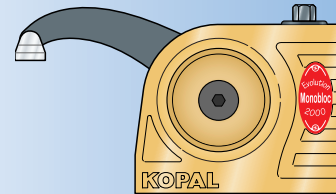

Duo

Worm screw

21-310

Straight arm

21-330

Bent arm

21-335

Clamping key

06-160

Swivel shoe

05-565

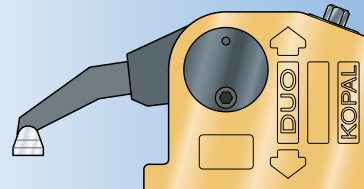

Big Block

Worm screw

1 screw, 1 smooth ring

08-325

Positioning pin

08-150

50 mm arm

08-315

95 mm arm

08-320

145 mm arm

08-322

245 mm arm

08-323

Clamping key

08-160

Swivel shoe

08-330

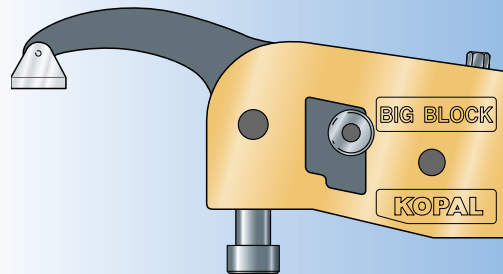

Maxibloc

Clamping screw

06-712

Adjusting screw

06-710

Clamping yoke nut

06-706

Clamping key

06-325

Extension key

06-726

Swivel shoe

06-330

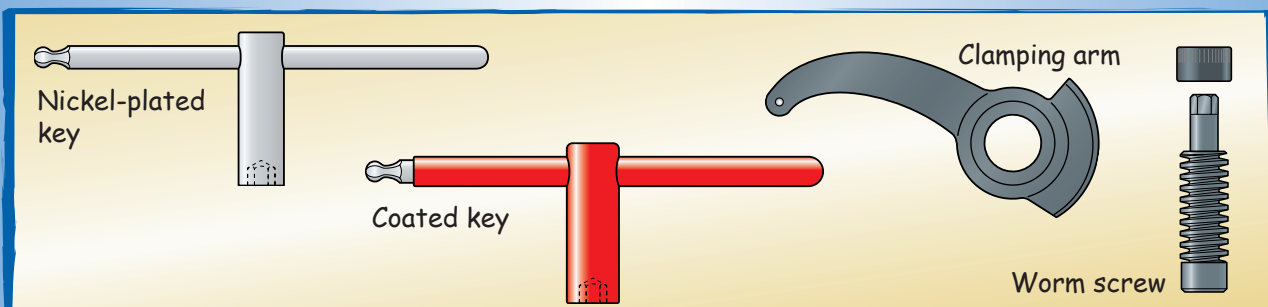
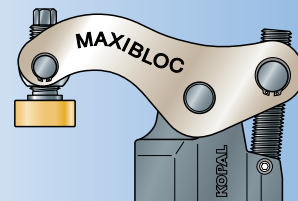

POWER REGULATING DISPATCHERS FOR VICES SAFETY COMPONENTS TABLE PROTECTION EQUIPMENT

● Table stops

● Environment

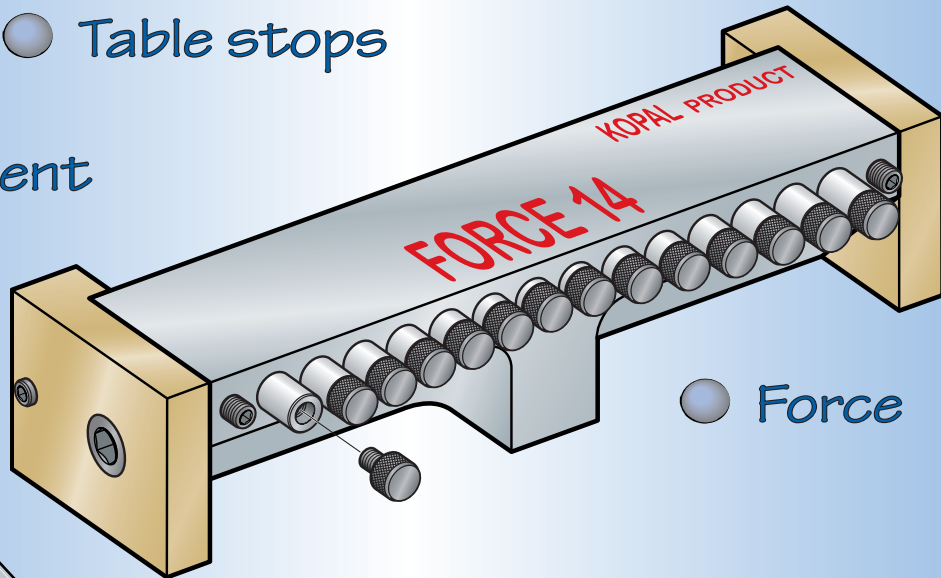

● Force

● Clip-on protectors

● Positioning locator

● Slot covers

● T-nuts

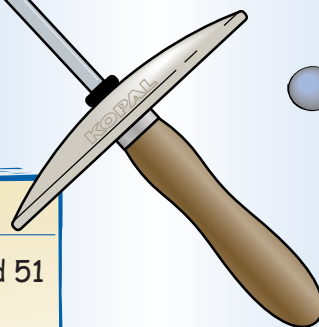

● Effectiveness

● Safety

Flash summary	
Power regulating dispatchers	50 and 51
"Force" for vices	
Slot covers	52
Cover holes for tables	53
T-nuts	54
Centring locator	54
Fixing screw	54
Stops and cams	55
Chip hooks	56
Pincers and cutters for chips	57
Clip-on protectors	57
Liquid absorbents	59

